



**Solutions for the
Water and Waste-
water Industry**
Tailor-made to
your application



 **Bauer**[®]
Gear Motor

Bauer geared motors can be used in many different applications

1 Intake pumping station

2 Rakes

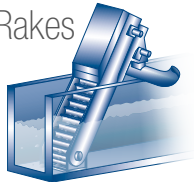

- » Bevel gear and parallel-shaft gear motors with hollow shaft and motor rating of **0.75 kW – 11 kW**.
- » Special corrosion resistance class **Coro 2**.
- » ATEX

3 Sand treatment

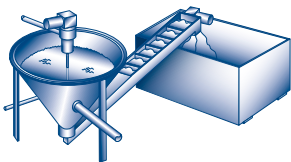

- » Parallel-shaft gear motors with hollow shaft and motor ratings of **0.55 kW to 1.5 kW**.
- » Special corrosion resistance class **Coro 2**.
- » ATEX

4 Primary sedimentation basin

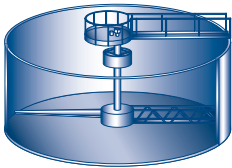

- » Parallel-shaft gear motors with hollow shaft and motor ratings of **0.12 kW to 2.2 kW**.
- » Special corrosion resistance classes **Coro 2 and 3**.
- » Suitable for continuous operation.

5
6 Aeration tanks

- » Helical gear motor with motor rating of **1.5 kW to 45 kW**.
- » Special corrosion resistance class **Coro 4**.
- » For continuous and submersible operation (**IP68**).

7 Blower station

- » Rotary blowers/air compressors driven by standard motors with a wide performance range.

8 Final sedimentation basin

9 Pumps/screw water pumps

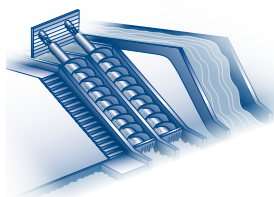

- » Parallel-shaft gear motors with hollow or solid shaft and motor ratings of **2.2 kW to 45 kW**.
- » Suitable for continuous operation.
- » Special flange available.

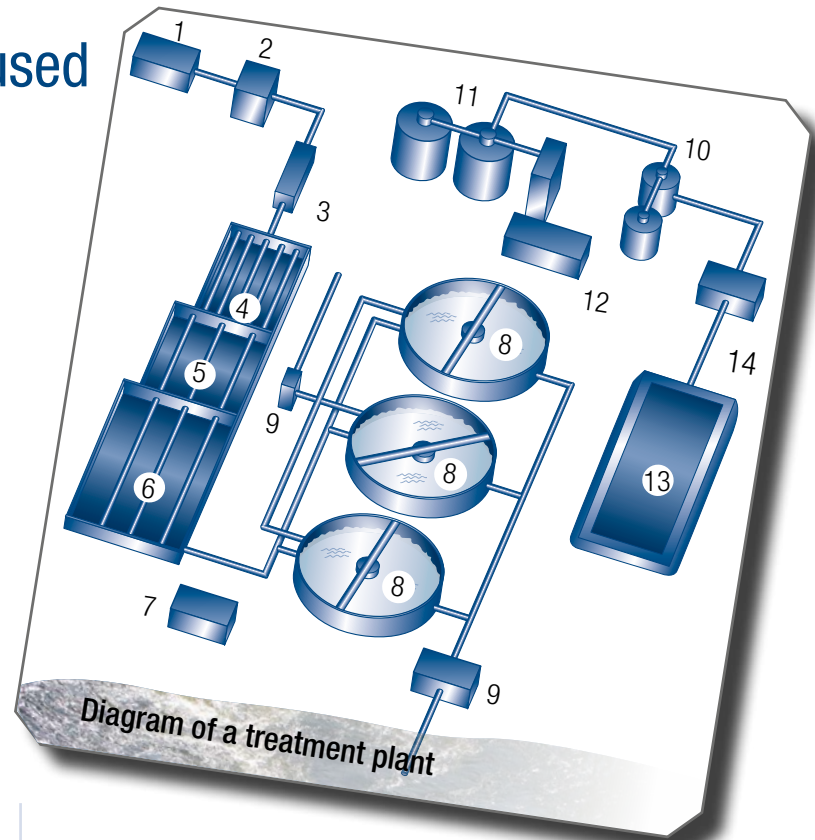

10 Sludge thickening/treatment

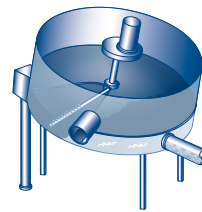

- » Parallel-shaft gear motors with motor ratings of **0.55 kW to 1.5 kW**.
- » Special corrosion resistance class **Coro 2**.
- » Suitable for use with inverters.

11 Septic tanks/Agitators

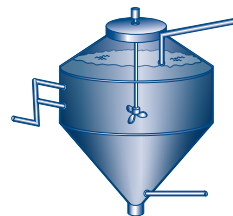

- » Bevel gear and parallel-shaft gear motors with agitator lanterns and motor ratings of **0.55 kW – approx. 30 kW**.
- » Special corrosion resistance class **Coro 2**.
- » Special “radial/axial load” flange available.

12 Block heating stations

13 Sludge collection container

14 Sludge dewatering/thickening

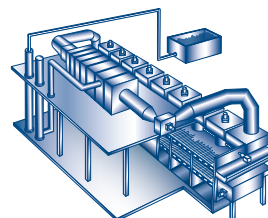

- » Bevel gear and parallel-shaft gear motors with motor ratings of **0.55 kW – 2.2 kW**.
- » Special corrosion resistance class **Coro 2**.
- » Suitable for use under high ambient temperatures **up to 80°C**.

You benefit from our application experience

Rakes

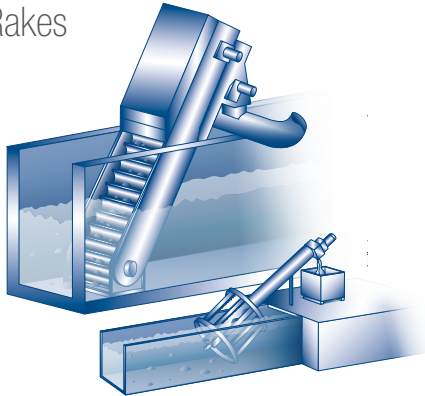

- Space saving by building the geared motor directly onto the machine.
- Thanks to the shaft-mounted gear motor, the radial/axial bearing and the shaft fixing on the rake are taken over by the gear.
- With an industrial geared motor there is no need for a tandem solution for large rakes with heavy loads, resulting in cost savings.
- By using Bauer premium efficiency motors with PMSM* technology, you can achieve up to 30 % energy savings even with the typical intermittent operation of the rake.
- PMSM motors (efficiency class IE3 and IE4) are also available for ATEX protection zone 1 under frequency inverter operation.

Wash press

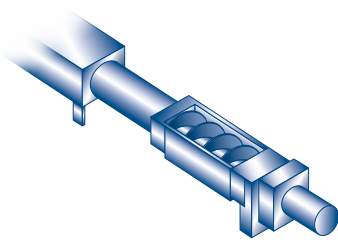

- Thanks to the reinforced bearings in the gears, the worm shaft can be incorporated directly into the gearing. As such, the customer needs one less bearing in the system.
- A special sealing design prevents foreign bodies penetrating into the gears during the washing process, which in turn reduces the maintenance frequency, increases the lifetime and guarantees process safety.
- PMSM motors (efficiency class IE3 and IE4) are also available for ATEX protection zone 1 under frequency inverter operation.

Sand treatment

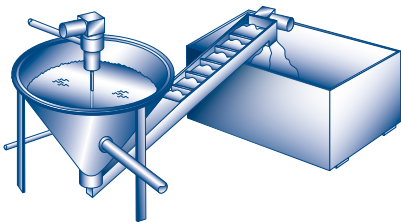

- Bauer geared motors with reinforced bearings increase lifetime and can absorb the high radial forces from the agitator shaft.
- From a gear size of 60 upwards, the gears can be fitted with agitator lanterns, in order to be able to absorb very high radial/axial loads.
- Using the PMSM technology, high initial torque and high efficiency are achieved across the entire range of applications, so reducing the operating costs by up to 30 %.

Sedimentation tanks

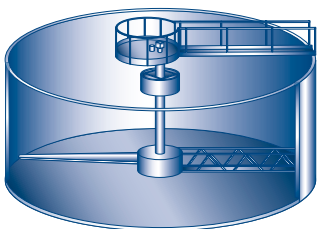

- A special paint delivers maximum corrosion protection and UV-stability for continuous operation in outdoor tanks (even close to the sea).
- Bauer geared motors with IP65 or IP66/67 protection as standard guarantee the highest reliability even in extreme environmental conditions.
- Bauer geared motors are designed for continuous operation and have exceptionally long service intervals (up to 25,000 hours), resulting in reduced maintenance costs.

* **PMSM = Permanent Magnet Synchronous Motor**

You benefit from our application experience

Pumps/screw water pumps

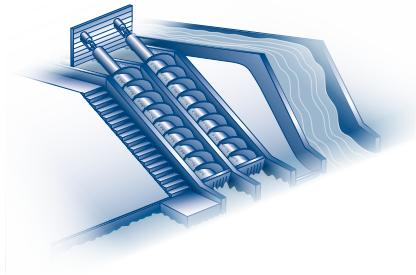

- Most pumps/screw water pumps run continuously with partial loads, so that by using Bauer premium efficiency motors with PMSM technology you can achieve huge energy savings of up to 40 % and short amortisation periods.
- Designed for continuous operation, Bauer geared motors guarantee high reliability, with long service intervals that reduce operating and maintenance costs.
- Using Bauer premium efficiency geared motors, the investment costs for IE3 and IE4 geared motors working with frequency inverters are significantly lower in the ATEX zone 1 area, compared to flame-proof motors.

Septic tanks/agitators

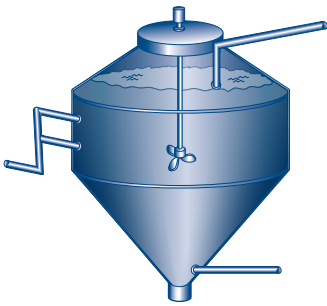

- Bauer geared motors are designed for continuous operation and have exceptionally long service intervals (up to 25,000 hours), resulting in reduced maintenance costs.
- Bauer Gear Motor also supplies planetary gear motors for very high torques, low speeds and small installation spaces.
- From a gear size of 60 upwards, the gears can be fitted with special agitator flanges that absorb the high radial/axial loads that are produced.
- Using the PMSM technology, high initial torque and high efficiency are achieved across the entire application range with small gear sizes and low power levels, reducing operating costs.

Sludge dewatering/thickening

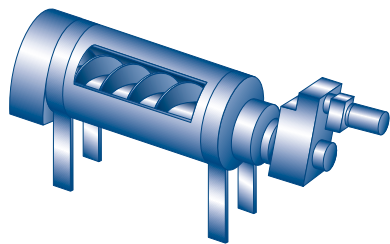

- Different rotation speeds and load ranges can be run synchronously with maximum torque and top efficiency thanks to the PMSM technology, resulting in a reduction in the number of variants possible.
- Very high initial torque can be handled by PMSM motors without a need for oversized motors, leading in turn to a reduction in weight and in the necessary power supply.
- Geared motors for the water screw pumps can be equipped with axial bearings, meaning that additional bearings on the machine are not required.

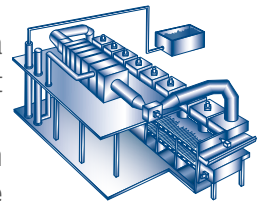

Solar drying

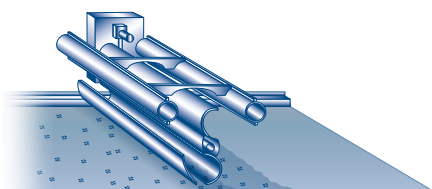

- Geared motors available for ambient temperatures up to +80°C and continuous operation.
- Bauer geared motors can also be used in ATEX Zone 1, and are approved for high ambient temperatures up to 60°C.
- Bauer-PMSM motors save energy across all working areas thanks to their high level IE3/IE4 efficiency.
- Bauer PMSM motors used in combination with an intelligent frequency converter make it possible to move loads with great precision and achieve accurate positioning without an encoder. By removing the encoder/initiators, the purchasing costs fall, and system errors and EMC interference are minimised.

Custom solutions - tailored to suit your application

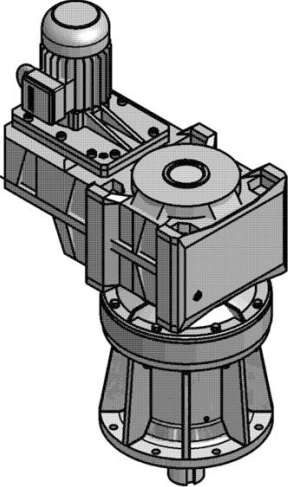
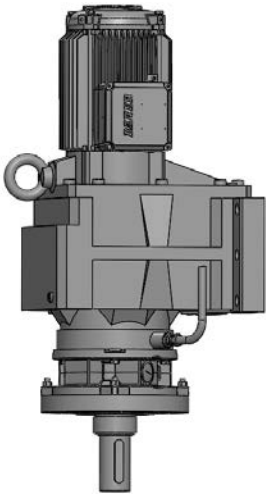
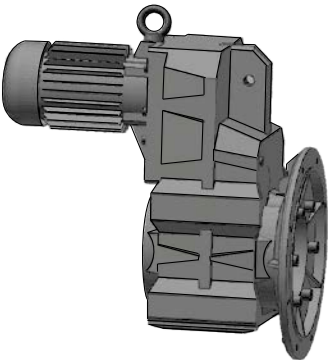
Agitators/mixers		<p>Function: To speed up the growth of the micro-organisms that devour the suspended solids it is necessary to introduce more air into the liquid, in order to optimise and speed up the process of cleaning the water.</p> <p>Demands on the drive:</p> <ul style="list-style-type: none"> • Suitable for continuous operation • Designed for very high radial load • Completely enclosed gears • Protection thanks to special gasket and coating <p>Solution: Parallel-shaft gear motor, e.g. BF80 in IP65</p> <p>Benefits:</p> <ul style="list-style-type: none"> • Special construction with larger bearing clearance (with long agitators high bending moments occur, this helps to support these) • Total gear motor in IP65 as standard, with “extremely high corrosion protection“ as an option • Drives also available for various ATEX and Nema explosion areas
Underwater aerator IP 68		<p>Function: By means of continuous mixing/swirling of the medium, oxygen is added to help bacterial growth.</p> <p>Demands on the drive:</p> <ul style="list-style-type: none"> • Continuous operation • High energy savings • Designed for permanent submersible operation • High reliability • Simple maintenance <p>Solution: Helical gear motor, e.g. BG70 with special sealing flange incl. leakage sensor</p> <p>Benefits:</p> <ul style="list-style-type: none"> • Completely enclosed and sealed gears • Special sealing design with mechanical seal • Optoelectronic leakage detection on the medium side and gear side (water/oil) • Special single cable solution (power supply/monitoring and sensors all on one cable) • Power cable easy to replace • Special IP68 plug for fast changing of cables
Screenings wash press		<p>Function: The collected screenings are washed with high-pressure fresh water jets and then dewatered and pressed using a screw</p> <p>Demands on the drive:</p> <ul style="list-style-type: none"> • High radial/axial loads accepted without the need for additional customer-side flanges/bearings • Special sealing design in the flange to deal with high pressure from screenings • ATEX Zone 1 <p>Solution: Parallel-shaft gear e.g. BF60 with special flange</p> <p>Benefits:</p> <ul style="list-style-type: none"> • All bearings are within the gear motor (flange) (axial + radial forces) • Special seal design integrated in gear flange • Special seal (high pressure and high dirt content) • Thanks to building the gear flange to suit specific customer needs, the costs were reduced, as the customer did not need to add additional seals /bearings.

The Bauer Geared Motor Product Range

Helical-Geared Motor
Series BG



Compact and economical inline helical geared motors for long lifetime under arduous conditions.

- Motor power from 0.03 kW to 75 kW
- 13 gearbox sizes for torques from 20 Nm to 18500 Nm
- New attachment possibilities with low design height
- High efficiency through 2 stage base design
- Enclosure IP65 as standard

Shaft-Mounted Geared Motor
Series BF



Shaft-mounted geared motors with integrated torque arm are easily integrated and economically applied.

- Motor power from 0.03 kW to 75 kW
- 10 gearbox sizes for torques from 90 Nm to 18500 Nm
- Gearbox housing with integral torque arm
- High efficiency through 2 stage base design
- Enclosure IP65 as standard

Bevel-Geared Motor
Series BK



Power-dense, right-angle, bevel-geared motors ensure the highest efficiency especially when used with frequency inverters.

- Motor power from 0.03 kW to 75 kW
- 10 gearbox sizes for torques from 80 Nm to 18500 Nm
- The right angle gearbox with universal attachment possibilities
- High efficiency through 2 stage base design
- Enclosure IP65 as standard

Worm-Geared Motor
Series BS



Economical, right-angle, worm-geared motors install easily in the tightest applications.

- Motor power from 0.03 kW to 5.5 kW
- 8 gearbox sizes for torques from 25 Nm to 1000 Nm
- Hollow shaft version already available from 25 Nm
- High loadable worm gearing for long lifetime
- Enclosure IP65 as standard

PMSM in IE4 for EX Areas
Series S



Permanent magnet synchronous motors (PMSM) Series S as variable-speed motors in efficiency class IE4 for use in explosion hazardous areas.

- Design torque MN: 5 Nm – 48 Nm
- Rated power PN: 0.75 kW – 15 kW
- Protection type: Increased Safety Zone 1
 - Ex II 2 G Ex e IIC T1 - T3 Gb
- Dust explosion protection Zone 21
 - Ex II 2 D Ex tb IIIC T 160°C ... 120° Db

Decentralised Inverter Geared
Motor Series



Decentralised inverter solutions are an integrated combination of geared motors and frequency inverter, which therefore offer extremely compact decentralised drive solutions.

- Saving space and costs
- No shielded motor cables required
- Mechatronic adaption of inverter and geared motor
- Motor power range 0.12 kW up to 7.5 kW
- Supply voltage 3 x 380 V - 480 V
- Compliance to all EMC standards
- CANopen, AS-i, PROFIBUS, EtherCAT, PROFINET and EtherNet IP communication interfaces
- STO (Safe Torque Off) and SIL 3 (Safety Integrity Level) safety functions
- UL approved

Top quality for a long lifetime

Main features

- Special paints protect against aggressive brines, alkalis and salts, as well as aggressive environmental conditions
- High standard enclosure IP65
- Optionally the following protection levels are available:
 - IP66, IP67, IP68
 - rain cover for fan cowls
 - cast terminal boxes
 - cable design
 - non-ventilated motors
 - stainless steel nameplate
 - galvanised fan cowls
 - special seals
 - IP66 brake

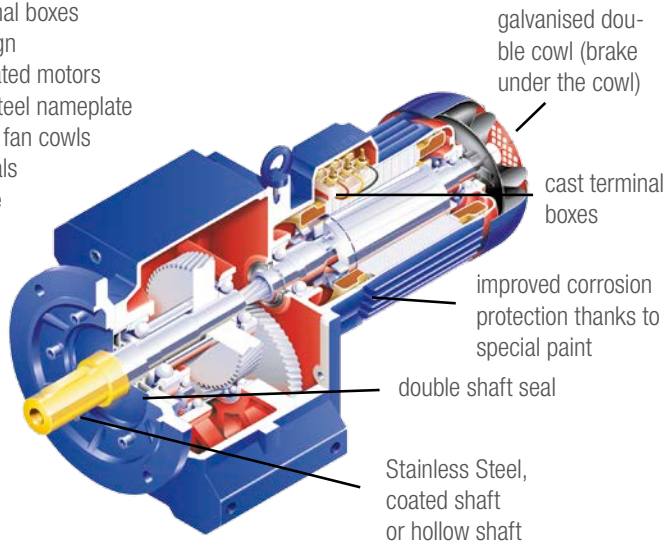

Standard Cage Clamp® terminals



with the following benefits:

- fast and secure connection of wires
- major time-saving, well-organised connection space, clear labelling of terminals
- total resistance to vibrations and shaking
- no risk of poorly attached cables or over-tightened screw connectors
- suitable for ex-protection

Terminal board available as option



Flexible motor mounting

Geared motor as integrated version

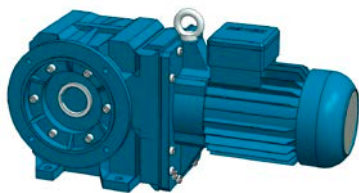

Bauer standard

- Good value solution, as the motor is integrated with the gearbox
- Short length
- Low weight
- ATEX
- IP68 possible

Geared motor with C/IEC flange

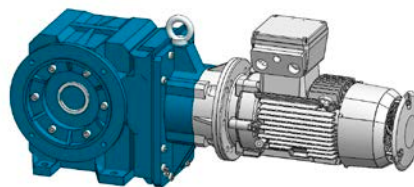

Bauer gears with C/IEC flange

- Bauer IEC motors can be built on
- Simple dry replacement of motor
- ATEX
- Any motors can be added on

Geared motor with C/Nema flange

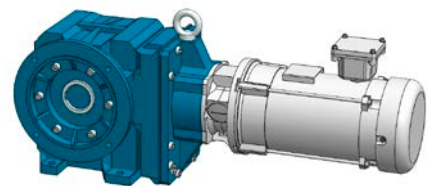

Bauer gears with C/Nema flange

- Nema standard
- Nema ex-protection (Class I: Division I)
- US motors can be built on (e.g. WEG, Baldor)
- UL/CSA compliant
- Backstop available
- IP68 possible

Industrial gears for high torques



Planetary gears up to approx. 1 million Nm are possible, if high torques are required at low rotation speeds and low weight. These are often used in sludge presses, agitators, etc.

Industrial bevel helical gears up to approx. 44,000 Nm are used anywhere that high torque is needed. They are used, for example, in large rakes, in agitators and with the screw water pumps.



Worldwide regulations for energy-saving standard motors

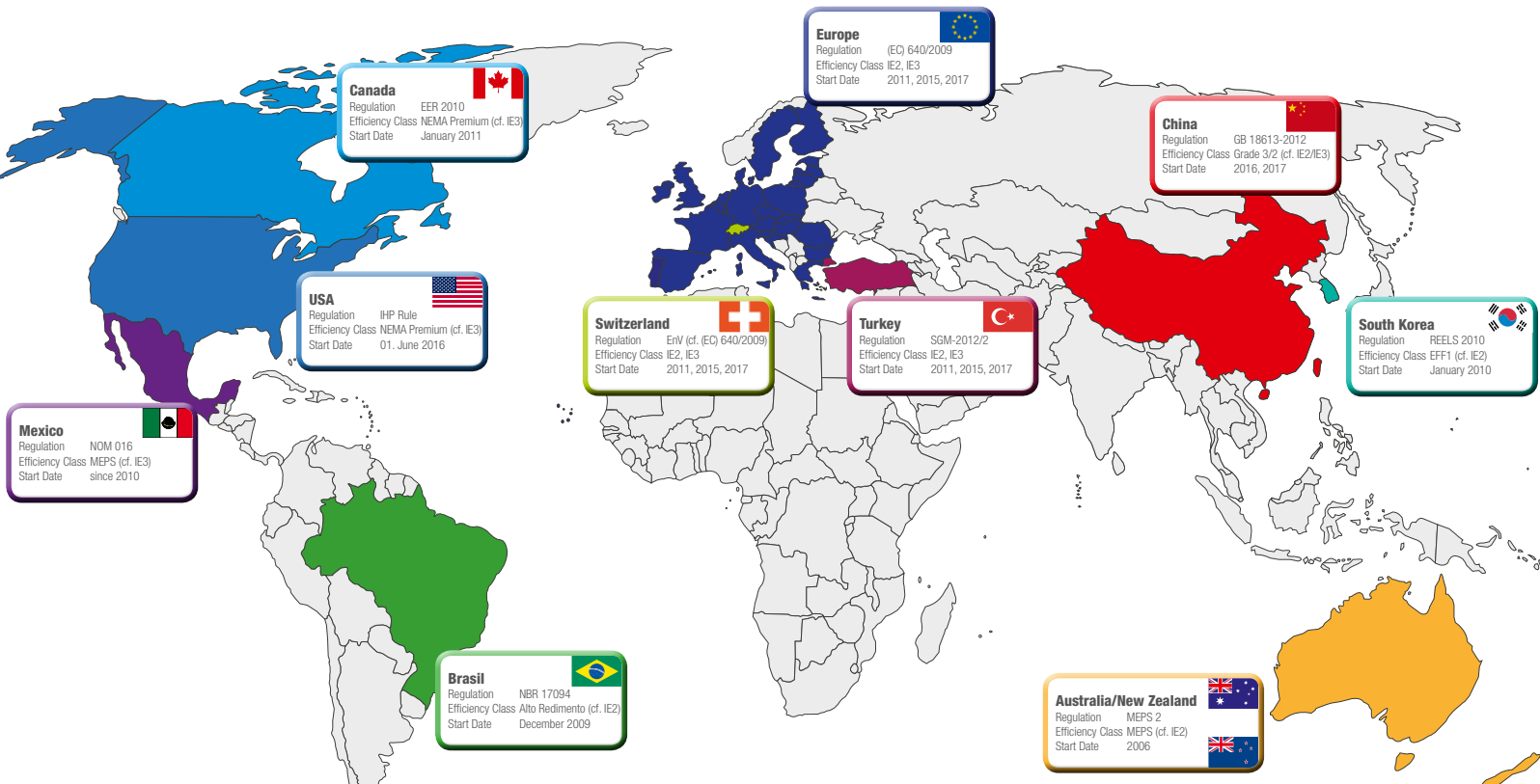

Motor technologies IE1 • IE2 • IE3 • IE4

IE-Class \ kW	0.12	0.18	0.25	0.37	0.55	0.75	1.1	1.5	2.2	3	4	5.5	7.5	9.5	11	15	18.5	22	30	37	45	
IE1 Induction	●	●	●	●	●	●	●	●	●	●	●	●	●	●	●	●	●	●	●	●	●	●
IE2 Induction	●	●	●	●	●	●	●	●	●	●	●	●	●	●	●	●	●	●	●	●	●	●
IE3 Induction	●	●	●	●	●	●	●	●	●	●	●	●	●	●	●	●	●	●	●	●	●	●
IE4 Induction					●	●	●	●	●	●	●	●	●	●	●	●						
IE3 PMSM								●	●	●	●	●	●	●	●	●						
IE4 PMSM		●	●	●	●	●	●	●	●	●	●	●	●	●	●							

● = planned

Benefits of permanent magnet technology

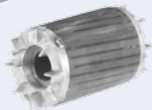
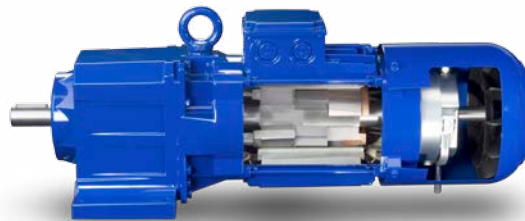

ALUMINIUM

Reference Losses 100%

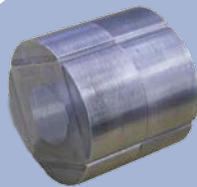

PERMANENT MAGNET

No voltage induction in the rotor

- No heat losses in the rotor
- Rotor losses reduced by 100%
- Total losses reduced by approximately 25%
- Total efficiency increased by more than 10%
- Partial load efficiency increased by more than 30%
- Synchronous speed
- High starting torque

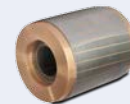

COPPER

Higher electrical conductivity of copper

- Rotor resistance reduces by 40%
- Heat losses in rotor reduced by 40%
- Total losses reduced by 10...15%
- Total efficiency increased by 1...2%

Properly protected in aggressive environments

IP65 Enclosure - the Bauer standard

- All components are designed for IP65
- Designed for industrial environments
- Resistant to dust and water entry
- Non-corrosive name plate
- Space heater
- Moisture and drip protection insulation
- Pressure vent
- Shaft seal on motor side
- Galvanised fan cowl
- IP65 brake

Paint coatings of a drive with CVS4 surface protection

CVS4 provides maximum corrosion protection for motors that are exposed to extreme environmental conditions and are used in aggressive environments or close to the sea.

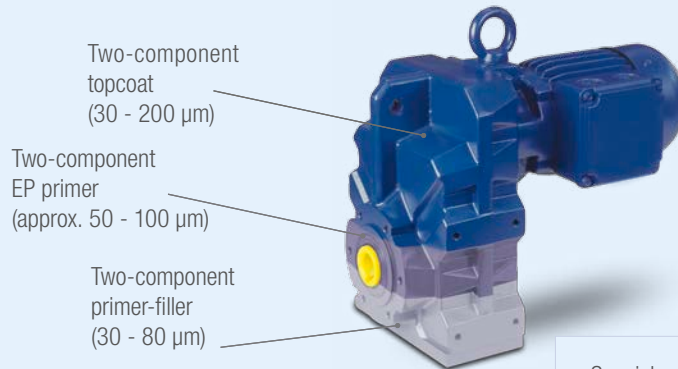

Special surface protection for the hollow shaft prevents fretting and other corrosion.



Types of seals

Depending on the application, the correct type of sealing technology is selected in order to guarantee the best possible leakage protection.

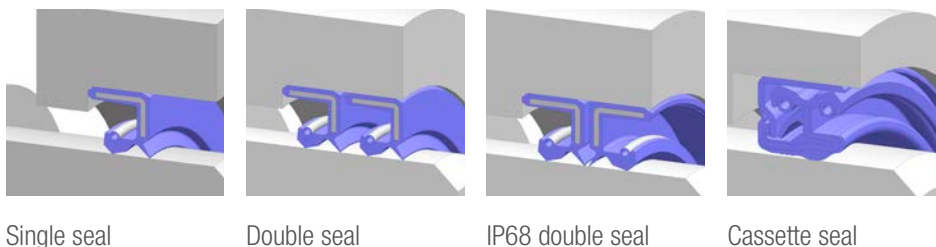

Degrees of protection provided by enclosures (IP xx)

1. Code number	Protected against foreign objects	2. Code number	Protected against water
0	not protected	0	not protected
1	Protected against solid foreign bodies of 50 mm diameter and greater	1	Protected against dripping water
2	Protected against solid foreign bodies of 12.5 mm diameter and greater	2	Protected against dripping water
3	Protected against solid foreign bodies of 2.5 mm diameter and greater	3	Protected against spray water
4	Protected against solid foreign bodies of 1.0 mm diameter and greater	4	Protected against splash water
5	Dust-proof	5	Protected against jets of water
6	Dust-tight	6	Protected against strong jets of water
		7	Protected against temporary immersion
		8	Protected against prolonged submersion
		9K	Protected against water during high pressure/steam jet cleaning

IP68 gear motor for submersible operation

IP68 geared motors are most suitable where it is required to convey or transport foul, waste, river or rain water, and all types of sludge-containing waters in communal or industrial areas. They are frequently used in agitators for mixing, homogenising, etc. or in extremely wet areas or completely submersed under water.

- Special design for continuous submersible operation
- Gear housing and motor are completely waterproof
- Maximum leakage protection
- Special seals available for the output shaft
- Electronic leakage detection is available for early recognition of errors
- Energy-saving asynchronous and permanent magnet motors up to IE4
- IP68 motors with brake available
- Gear motor can be operated at constant power in air or in a medium
- Fully cast cable to ensure maximum level of sealing
- Usable down to water depths of 5 m (greater depths also possible)
- Special coating allows extreme underwater conditions (coating resistant against many aggressive chemicals)
- Optionally also available with plug version of the cable
- Power classes: 0.37 – 11 kW
- Use in potentially explosive atmospheres possible (e.g. Atex Zone 1)

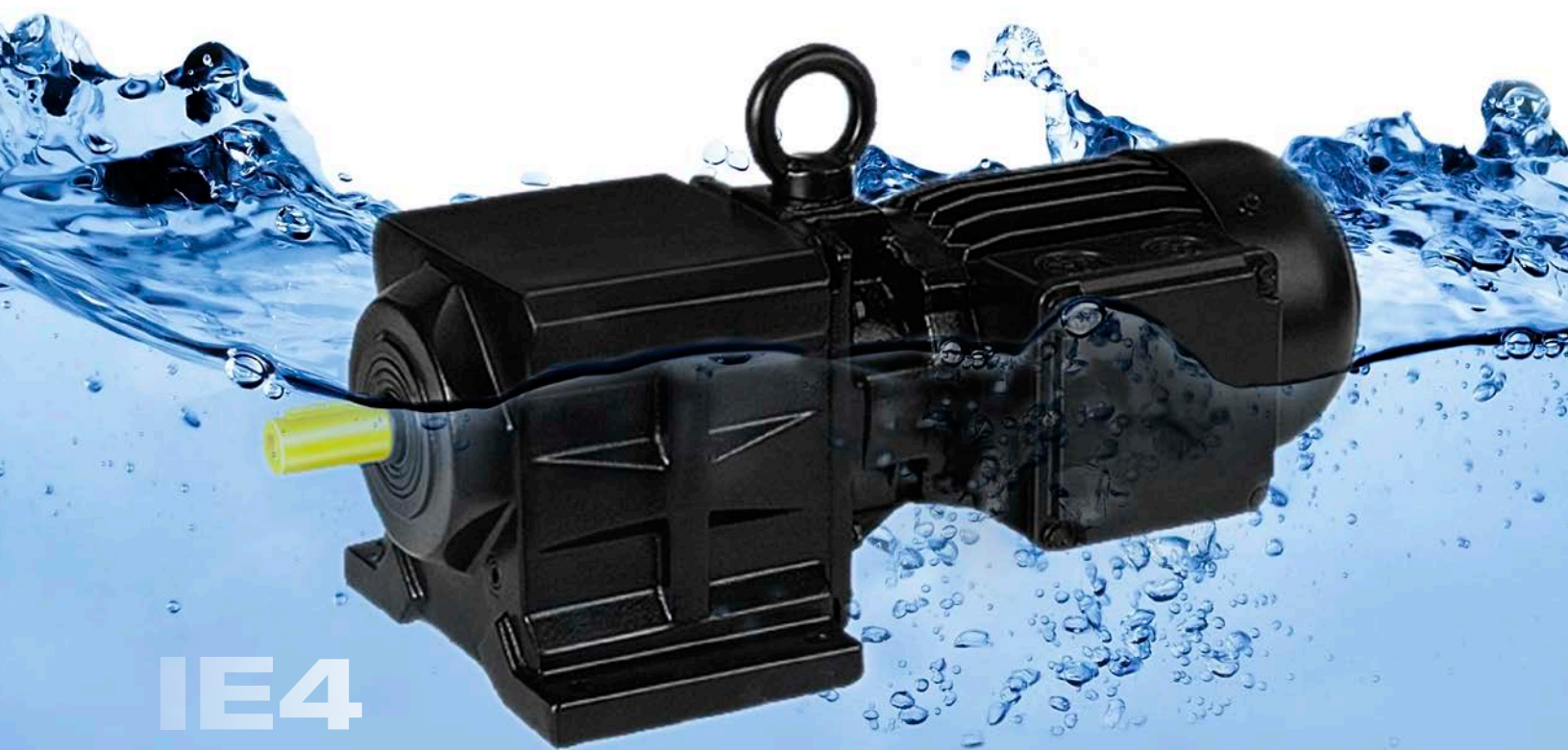

IE4

high
corrosion protection

customised sealing systems

stainless steel shafts

advanced coating systems

IP68

leakage sensors

Enclosure IP68 for greater safety

- **Shafts** can alternatively be made
 - of stainless **V4A steel**
 - or with special surface coating
- **Reinforced ball bearings** for higher strength or longer lifetime
- **Special sealing concepts** can be adapted depending on the environment (e.g. mechanical seals, cassette seals, etc.)
- **Brakes in IP68:** With built-in spring-loaded brakes, brakes are applied when the voltage is switched off
- The **direct current brake coil** is directly supplied with direct current or with alternating voltage via an external rectifier
- **Motor protection:** For temperature protection, thermistors or thermostats can be integrated into the winding
- **Motor connection:** The terminal box is cast with a special resin so that no moisture/liquids can penetrate into the motor. Errors due to poorly tightened terminal box covers are prevented.

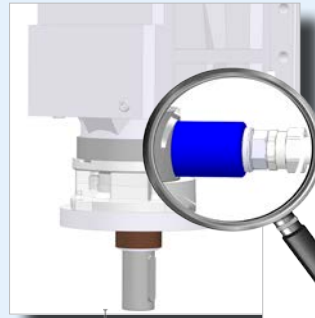

Leakage detection:
Leakage can be detected early with an electronic sensor.

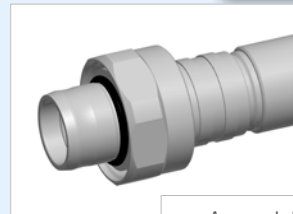

A special plug connection is available for up to 30 bar. This makes it easy to replace cables without disassembling the motor.

Paint coatings of a „CVS5-M“ IP68 drive

High-quality CVS5-M coating with a coating thickness of at least 400 µm guarantees maximum corrosion protection, high chemical resistance and tightness of the geared motors.

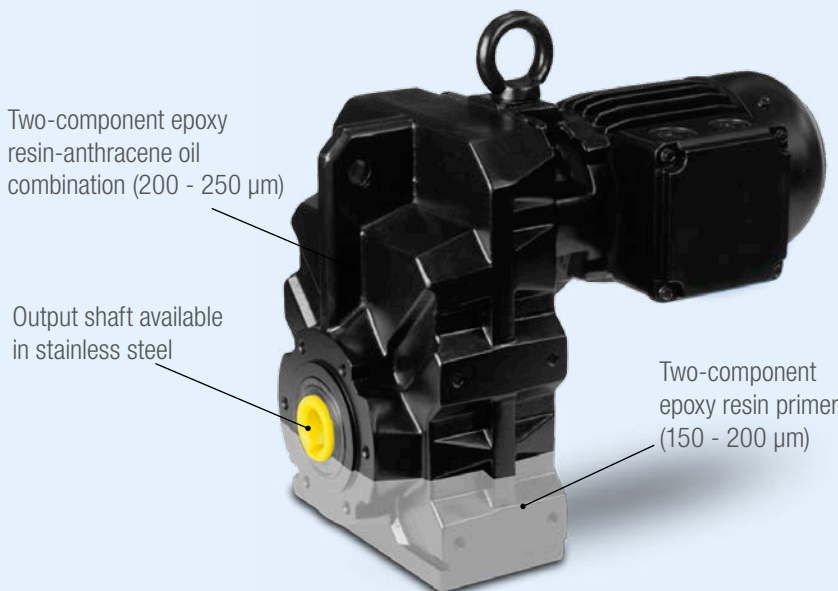

BF series



BG series



BK/BS series

EtaK2.0

Flexible due to modular design

The EtaK2.0 features maximum user-friendliness in operation and installation. Especially for decentralised drive solutions, it demonstrates its high efficiency in terms of space, time and energy.

- Integrated safety technology and field bus communication according to individual requirements
- VFC eco mode offers an intelligent adjustment of the magnetising current
- Energy savings of up to 30 % possible in partial load range
- Asynchronous motors and PM synchronous motors can be operated
- Suited to the harshest environments thanks to the high enclosure IP65.
- Direct current braking
- Overload current
 - 200% (3 s)
 - 150% (60 s)

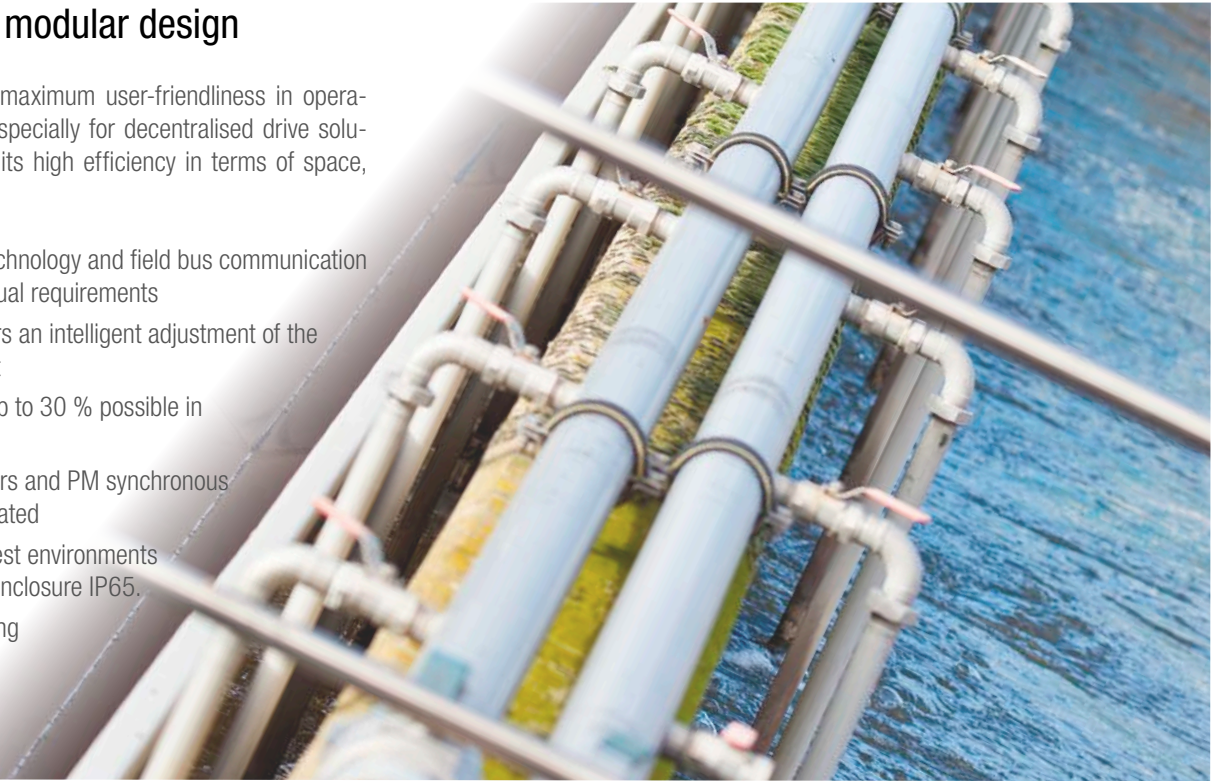

Drive Unit



Power unit - few variants

- Power unit with 3 designs available with 10 power ratings
- BF1: Voltage: 380 - 500 V (3ph)
Power: 0.37 to 1.5 kW
- BF2: Voltage: 380 - 500 V (3ph)
Power: 2.2 to 3.0 kW
- BF3: Voltage: 380 - 500 V (3ph)
Power: 4.0 to 7.5 kW
- Enclosure IP65

Communication Unit



Functionality on site

- Communication via CANopen, PROFIBUS, PROFINET, EtherCAT, EtherNET/IP and AS-interface
- Safety functions in accordance with EN 60204 (STO, SS1)
- Processing of I/O signals
- Without field bus: I/O via screw connections
- With field bus: bus and 2 input signals via M12
- Customised: up to max. 8 M12
- Pre-assembled M12 plugs available as accessories

Connection Unit



Flexible connection options

- Screwed cable gland and various plug connections
- Connection for braking resistor
- Spring-set brake control



Motor efficiency in practice

In most applications, geared motors do not work at their nominal operating point. Although the motor nameplates indicate high efficiency levels at the nominal operating points, in reality these values fluctuate heavily because motors are mostly run at between 30 and 70% of the nominal load. Under precisely these working conditions there can be large fluctuations in the level of efficiency and therefore in the energy savings. With the Bauer premium efficiency motors, high efficiency levels can also be achieved in this load range and therefore the user can also make energy savings of over 30%.

The diagram below compares the different curves for the different motor technologies (ASM vs PMSM) at the same efficiency class IE3. It also shows a curve for an IE2 ASM motor for comparison purposes.

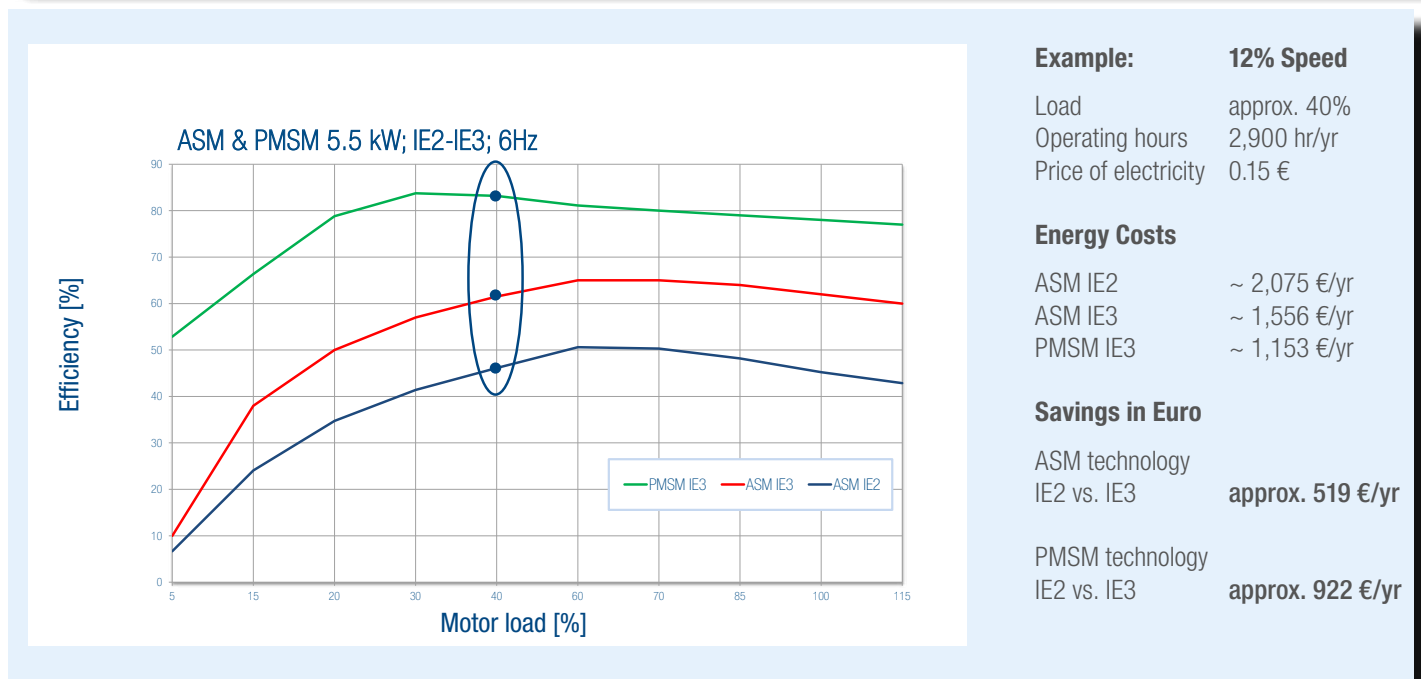
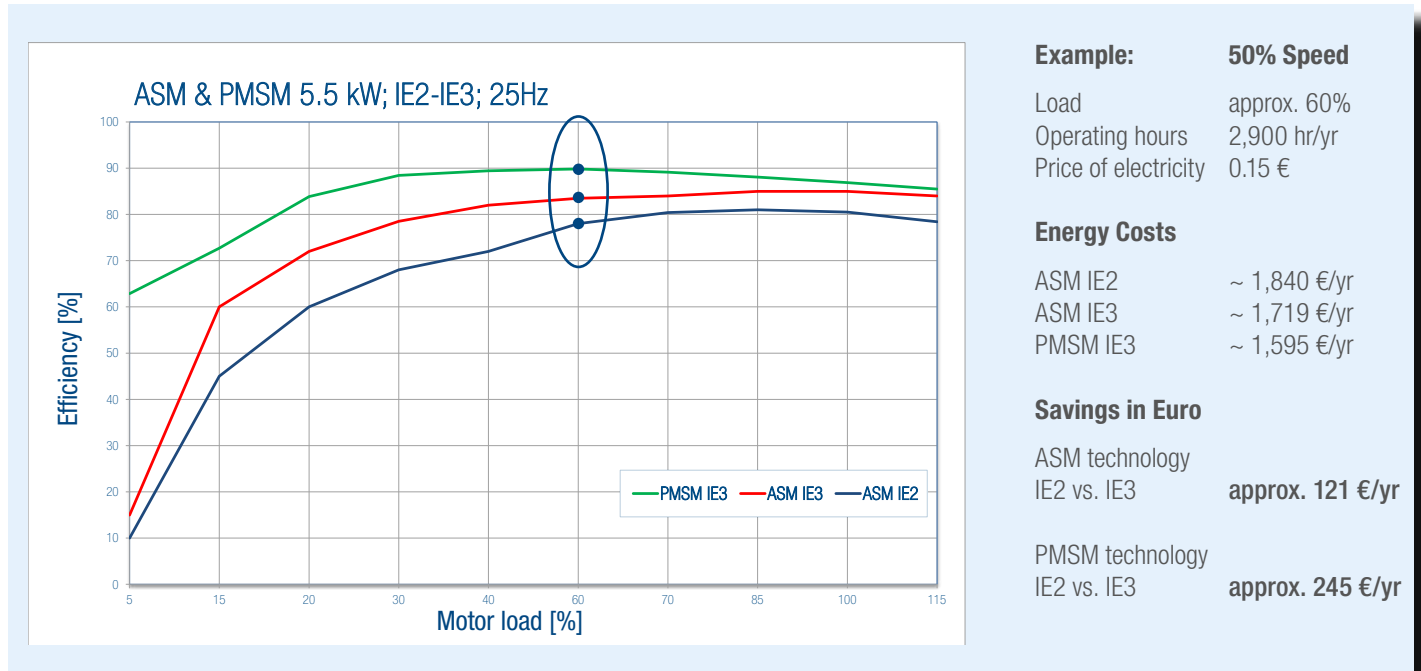

Histogram 3D efficiency level asynchronous vs. PMSM

Histogram efficiency level IE3 ASM motor

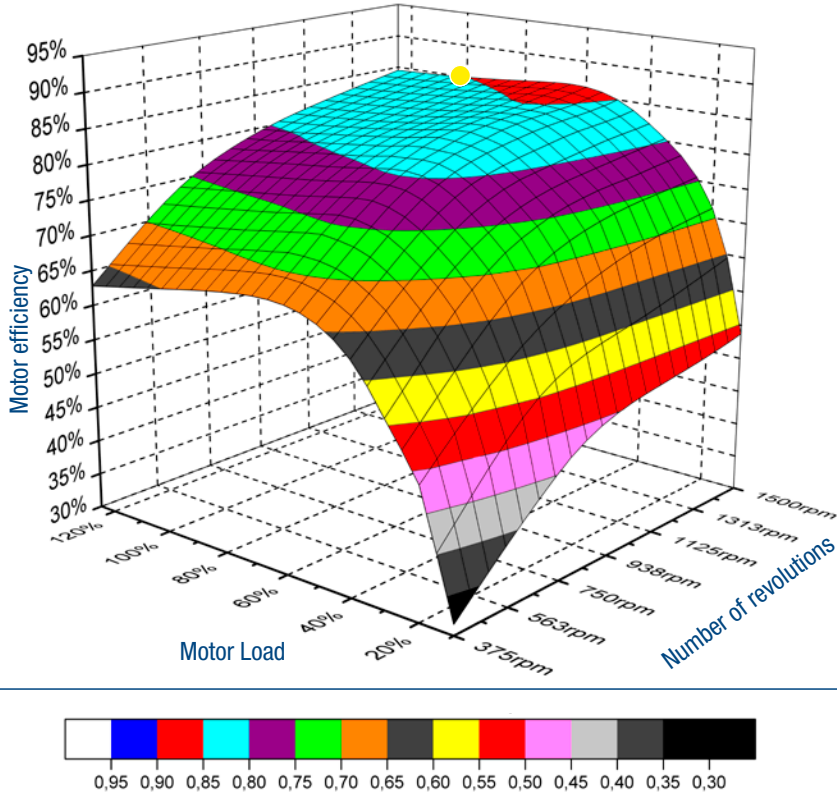

The IE3 asynchronous motor with 1.1 kW power in the diagram shown to the left has an efficiency of approx. 85% at the nominal point (shown in light blue - yellow dot). This high level of efficiency is only available in a very small operational range and drops quickly depending on the speed and load.

The lower the load on the motor or the speed of the motor, the lower the efficiency of the motor becomes.

Efficiency histograms make it possible to determine the actual level of efficiency for every operating point on the motor for the purposes of conducting a TCO calculation.

Operation with a partial load or a lower speed will not utilise all of the energy benefits of an IE3 ASM motor.

Histogram efficiency level Bauer IE3 Premium Efficiency Motor

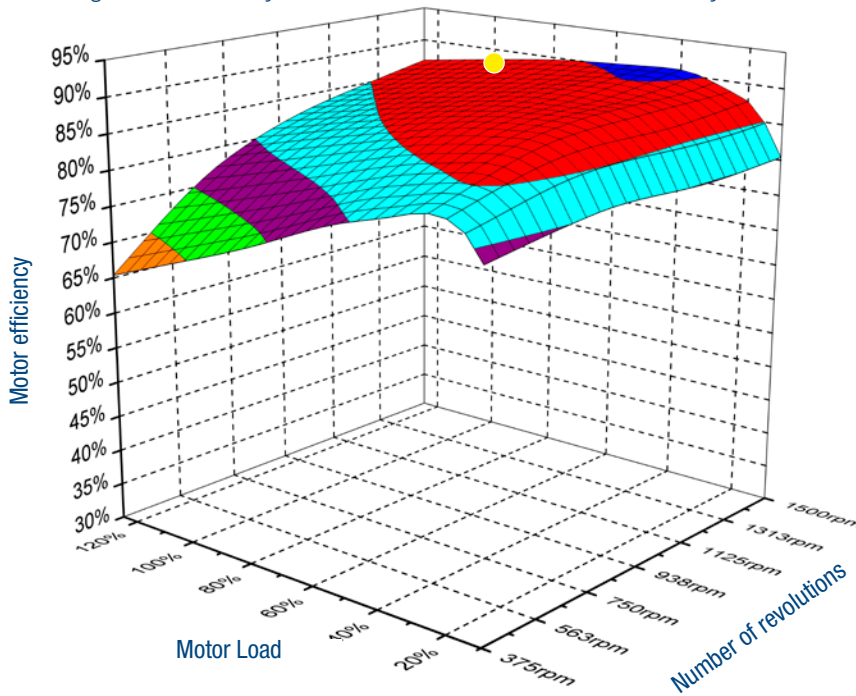

An IE3 Permanent Magnet Synchronous Motor (PMSM) with 1.1 kW power presents a much more even diagram than the IE3 ASM in the diagram above. The efficiency is approx. 88.4% at the nominal point (shown in dark red - yellow dot). When operated with a partial load, however, the efficiency increases to over 90% (shown in blue). The high level of efficiency (shown in dark red) generally covers a large area in such a way that high levels of efficiency are possible during partial load operation or at low speed. And the motor's extreme points, e.g. minimum load and minimum speed, have a clearly improved level of efficiency compared to the ASM.

The colours used in both diagrams represent the same level of efficiency. This makes it quick and easy to compare them.

You can clearly see for the PMSM motor that at almost every operational level of the motor there is a very high level of efficiency, and therefore it is very energy efficient.



Efficiency comparison pumping system

An increasing number of pumps are now being run using speed control in order to be able to define the dynamic volume flow. The pump's quadratic characteristic causes the motor load to decrease rapidly at lower speeds, which results in the level of efficiency decreasing significantly.

Using the diagrams, it can be seen that the ideal workload for the existing asynchronous motor is not reached, due to operation at partial loads (approx. 30%) and speeds (75%).

If the pump is then equipped with a PMSM motor that has an extended efficiency range including partial load operation, the level of efficiency can be in-

previous solution	present solution using Bauer geared motors
4 kW motor	3 kW motor
IEC motor 132	IEC motor 112
no IE class	IE3
Asynchronous motor	Bauer PMSM motor

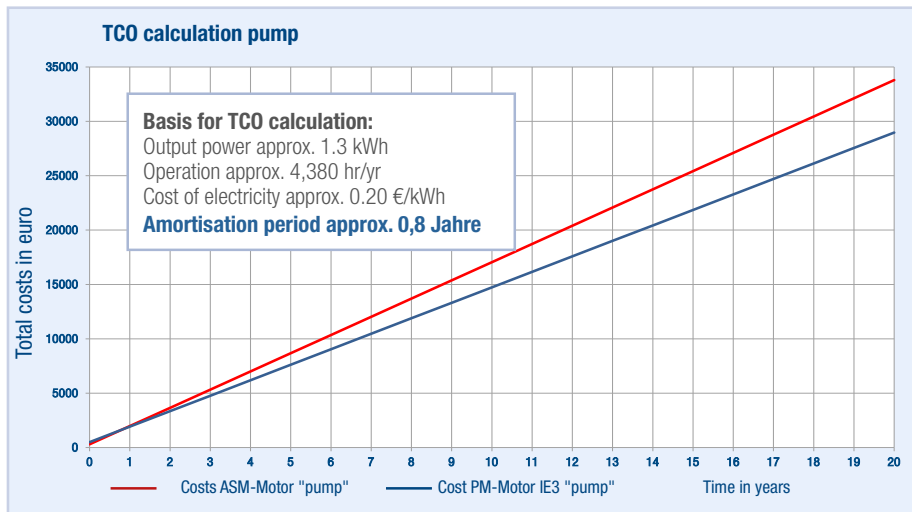
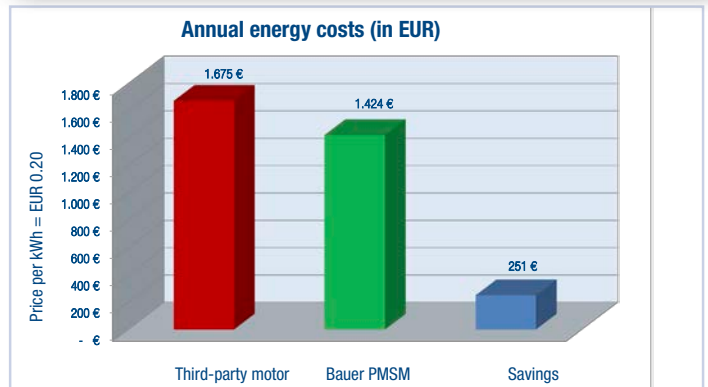
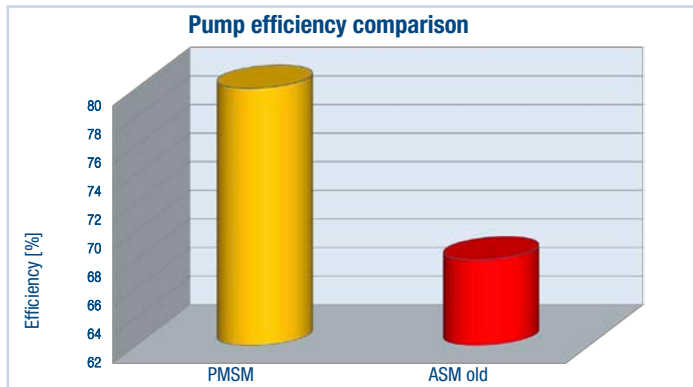

creased by approx. 12% in this example and savings of more than **EUR 250** per pump per year can be achieved (depending on the number of hours' operation per year).

The PMSM technology offers a major benefit above all for applications that run at partial load levels and variable speeds, allowing energy savings to be made. This means that the slight price increase for a new technology is amortised within just 10 months. And not only the efficiency is increased, also the gear size and weight can be reduced thanks to the higher performance density. Using the "synchronous operation" that it imposes, an exact flow level can be achieved e.g. with piston pumps.



Efficiency comparison disk thickener

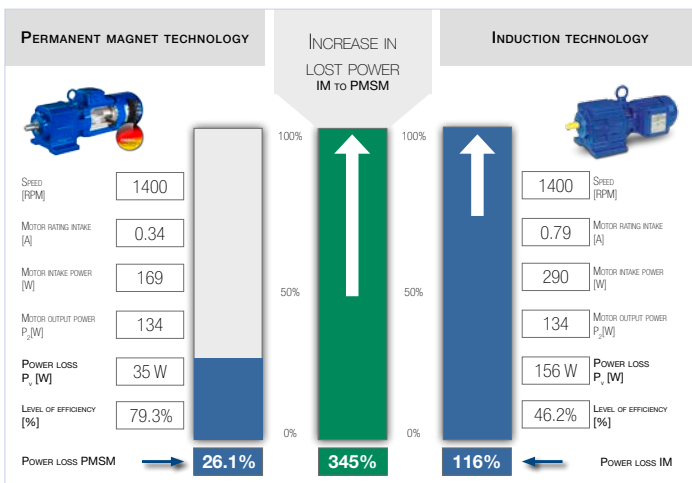

previous solution	present solution using Bauer geared motors
0.37 kW Motor	0.55 kW Motor
IEC motor 71	IEC motor 80
no IE class	IE4
Asynchronous motor	Bauer PMSM motor

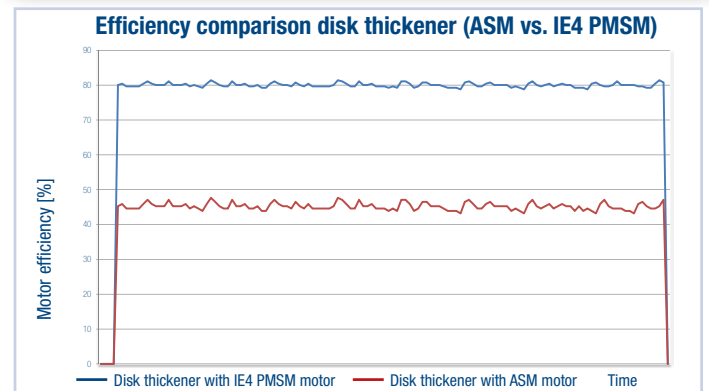

For the “disk thickener” machine, an asynchronous motor with an output of 0.37 kW was replaced by an IE4 PMSM motor of 0.55 kW.

It can be seen clearly in the diagram that the power uptake is very low for this application. So the actual load on the 0.37 kW asynchronous motor is approx. 40%, for the PMSM motor with 0.55 kW only 25%, of the actual motor performance.

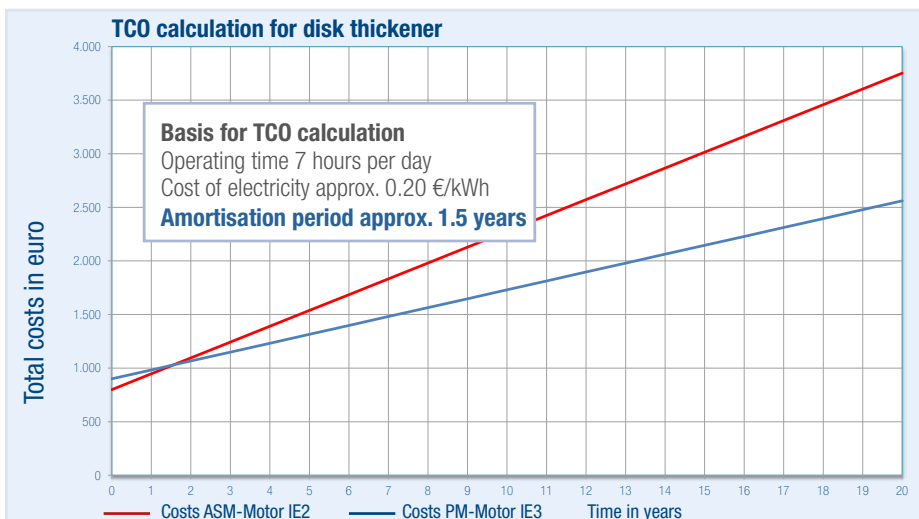

This operation at partial loads causes the efficiency level of the asynchronous motor to deteriorate significantly. When running the disk thickener the ASM achieves an efficiency level of approx. 46%. The over-sized PMSM motor on the other hand, thanks to its technology was able to offer a higher/broader area of efficiency and achieved nearly 80% efficiency.

Given the long periods of operation and the high efficiency level, the new motor technology is amortised within 2 years and after that starts to deliver savings in energy costs for the customer.



Efficiency comparison rakes

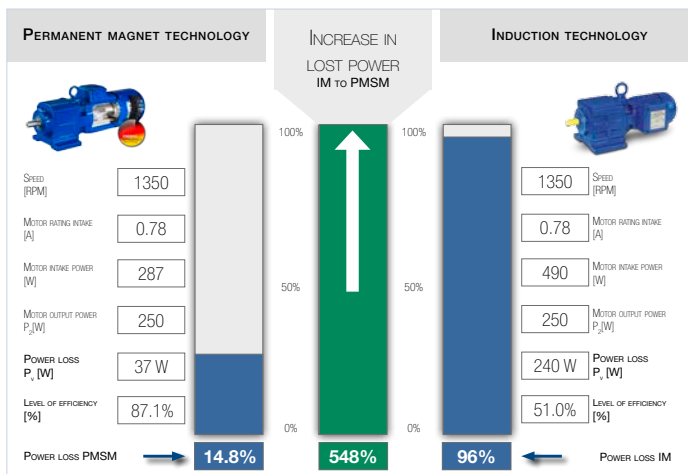

previous solution	present solution using Bauer geared motors
2.2 kW motor	2.2 kW motor
IEC motor 90	IEC motor 80
IE2	IE3
Asynchronous motor	Bauer PMSM motor
ATEX Zone 1	ATEX Zone 1

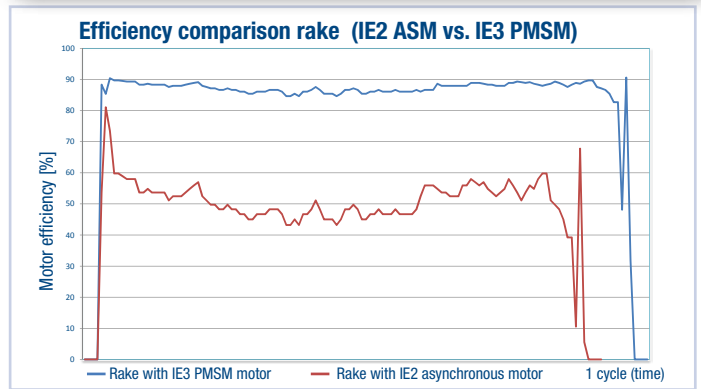

A presentation of the TCO and energy usage was also prepared for a rake, which runs all the time but in an intermittent pattern. PMSM motors also offer benefits for applications which are not running continuously.

Because this rake is running at about 10% load, the efficiency level of the motor falls off for this application. Even if there is no energy management due to the continual switching on and off 56-60%, by using a different motor technology “energy” can be saved. Using a cycle diagram you can

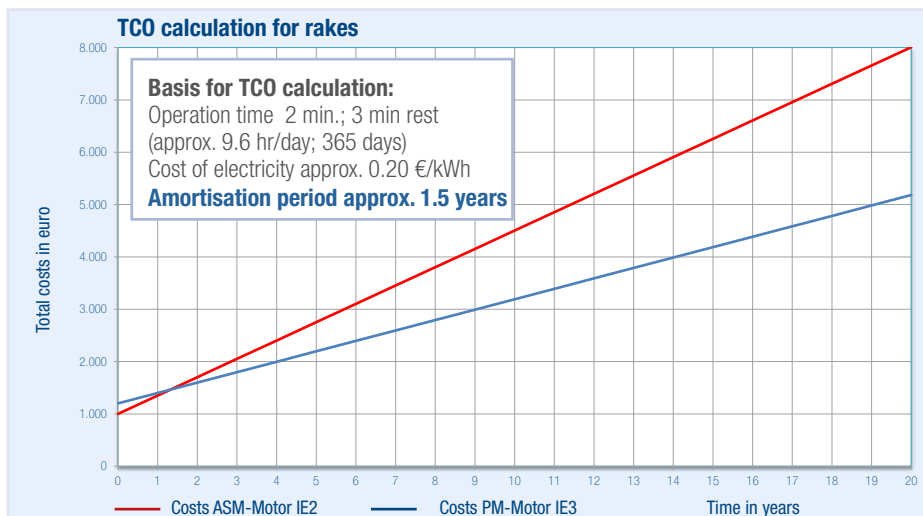

see that on start-up, high torque is needed and therefore the motor needs to be oversized.

When the rake is running, the motor’s load uptake falls to approx. 10% of its rated power. Consequently, the efficiency of the ASM motor drops as a result of the low partial load. Using an ultra energy-efficient PMSM motor makes it possible to achieve close to the nominal efficiency even during operation with a partial load. As such, energy savings are guaranteed even with intermittent operation. This new motor technology is amortised within just 2 years.

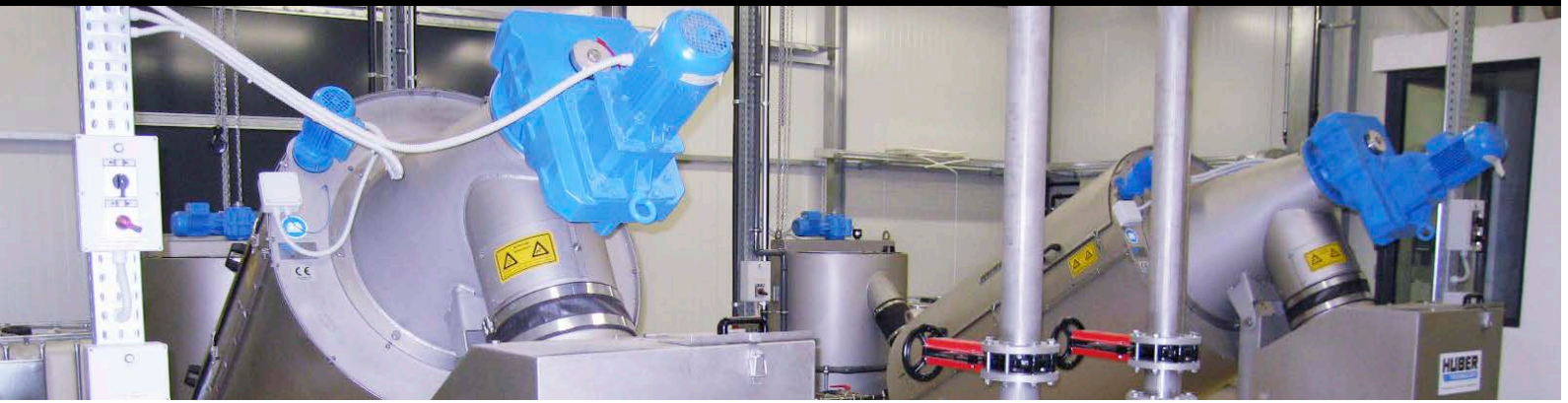

Efficiency comparison **sludge press**

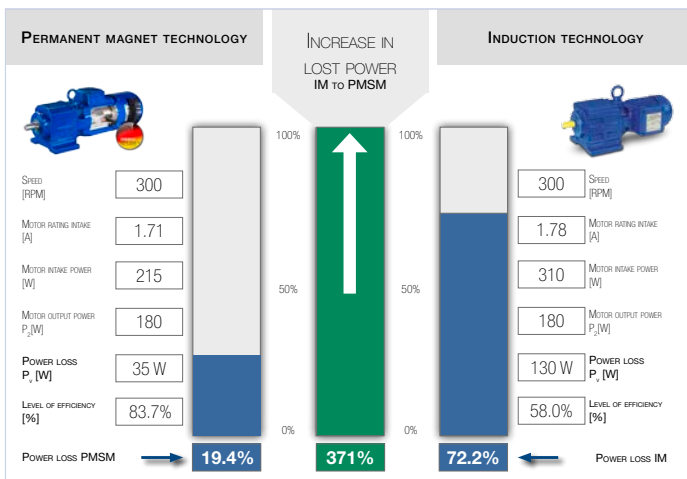

previous solution	present solution using Bauer geared motors
2.2 kW motor	2.2 kW motor
IEC motor 90	IEC motor 80
IE2	IE3
Asynchronous motor	Bauer PMSM motor

In a treatment plant, the energy consumption and motor efficiency of a sludge press were investigated. The measurements were taken and recorded while using an IE2 asynchronous motor and an IE3 PMSM motor.

As a high speed and low torque is required in the rinsing cycle, and a low speed and high torque is required during press operation, a wide adjustment range must be available for the motor. As you can see from the diagrams, the machine in this example is operating at approx. 300 rpm (motor speed) and approx. 10% load. The high starting torque (approx.

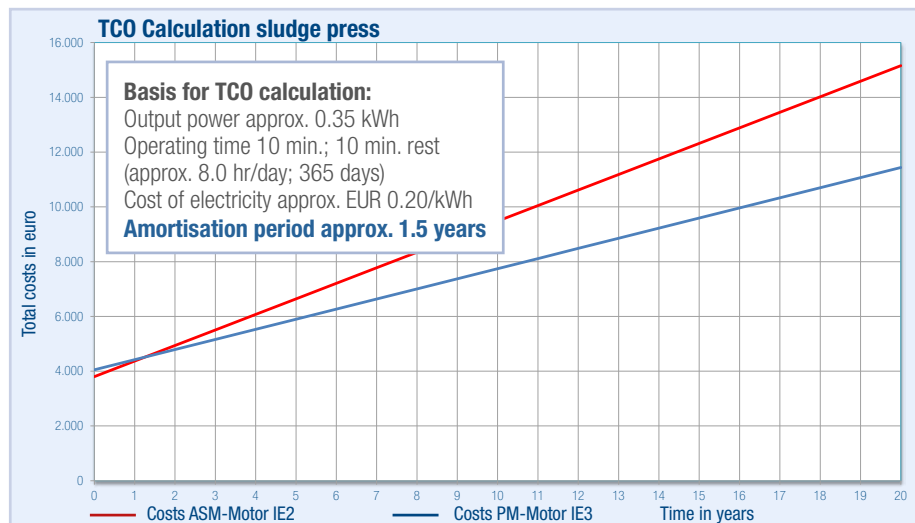
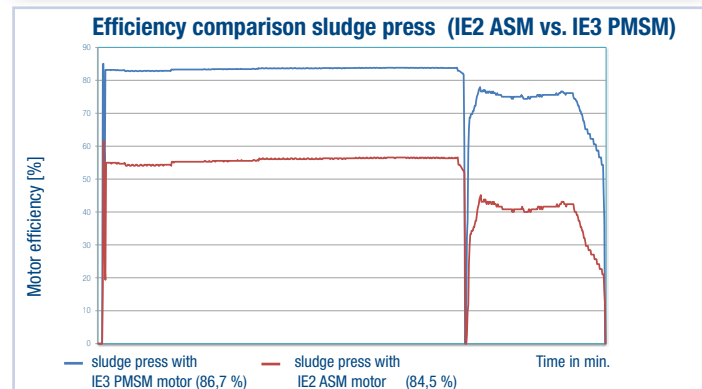

3.5 times higher) available from the motor is required briefly, usually when starting up or when carrying out compression.

Under these extreme operating conditions, the efficiency of the asynchronous motor falls sharply. The PMSM motor really comes into its own, thanks to its extended efficient working range under partial loading, and delivers a short amortisation period of less than 2 years. Thanks to the motor's synchronous running, a stable speed can be used for the sludge presses at all levels of speed, as well as achieving very high start-up/initial torque using smaller motors.

Couplings

Ameridrives Couplings*Mill Spindles, Ameriflex, Ameridisc*

Erie, PA - USA

1-814-480-5000*Gear Couplings*

San Marcos, TX - USA

1-800-458-0887**Bibby Turboflex***Disc, Gear, Grid Couplings,
Overload Clutches*

Dewsbury, England

+44 (0) 1924 460801

Boksburg, South Africa

+27 (0) 11 918 4270**TB Wood's***Elastomeric Couplings*

Chambersburg, PA - USA

1-888-829-6637 – Press #5*For application assistance:
1-888-829-6637 – Press #7**General Purpose Disc Couplings*

San Marcos, TX - USA

1-888-449-9439**Ameridrives Power Transmission***Universal Joints, Drive Shafts,
Mill Gear Couplings*

Green Bay, WI - USA

1-920-593-2444**Huco Dynatork***Precision Couplings
and Air Motors*

Hertford, England

+44 (0) 1992 501900

Chambersburg, PA - USA

1-888-829-6637**Lamiflex Couplings***Flexible Couplings, Bearing Isolators,
and Coupling Guards*

São Paulo, SP - Brasil

+55 (11) 5679-6533**Guardian Couplings***Flywheel, Jaw, Shear, Gear, Grid,
Disc and Engine Couplings*

Michigan City, IN - USA

1-219-874-5248Engineered
Bearing Assemblies**Kilian Manufacturing***Engineered Bearing Assemblies*

Syracuse, NY - USA

1-315-432-0700Electromagnetic
Clutches and Brakes**Warner Electric***Electromagnetic Clutches
and Brakes*

New Hartford, CT - USA

1-800-825-6544*For application assistance:
1-800-825-9050*

Saint Barthélemy d'Anjou, France

+33 (0) 2 41 21 24 24*Precision Electric Coils and Electro-
magnetic Clutches and Brakes*

Columbia City, IN - USA

1-260-244-6183**Matrix International***Electromagnetic Clutches
and Brakes, Pressure Operated
Clutches and Brakes*

Brechin, Scotland

+44 (0) 1356 602000

New Hartford, CT - USA

1-800-825-6544**Inertia Dynamics***Spring Set Brakes; Power On and
Wrap Spring Clutch/Brakes*

New Hartford, CT - USA

1-800-800-6445

Overrunning Clutches

Formsprag Clutch*Overrunning Clutches
and Holdbacks*

Warren, MI - USA

1-800-348-0881 – Press #1*For application assistance:
1-800-348-0881 – Press #2***Marland Clutch***Roller Ramp and Sprag Type Over-
running Clutches and Backstops*

South Beloit, IL - USA

1-800-216-3515**Stieber Clutch***Overrunning Clutches
and Holdbacks*

Heidelberg, Germany

+49 (0) 6221 30 47 0

Belted Drives and Sheaves

TB Wood's*Belted Drives*

Chambersburg, PA - USA

1-888-829-6637 – Press #5*For application assistance:
1-888-829-6637 – Press #7*Heavy Duty
Clutches and Brakes**Wichita Clutch***Pneumatic Clutches and Brakes*

Wichita Falls, TX - USA

1-800-964-3262

Bedford, England

+44 (0) 1234 350311**Twiflex Limited***Caliper Brakes and Thrusters*

Twickenham, England

+44 (0) 20 8894 1161**Industrial Clutch***Pneumatic and Oil Immersed
Clutches and Brakes*

Waukesha, WI - USA

1-262-547-3357**Svendborg Brakes***Industrial Brakes and
Brake Systems*

Vejestrup, Denmark

+45 63 255 255

Gearing

Boston Gear*Enclosed and Open Gearing,
Electrical and Mechanical
P.T. Components*

Charlotte, NC - USA

1-800-825-6544*For application assistance:
1-800-816-5608***Bauer Gear Motor***Gearred Motors*

Esslingen, Germany

+49 (711) 3518-0

Somerset, NJ - USA

1-732-469-8770**Nuttall Gear and
Delroyd Worm Gear***Worm Gear and
Helical Speed Reducers*

Niagara Falls, NY - USA

1-716-298-4100

Linear Products

Warner Linear*Linear Actuators*

Belvidere, IL - USA

1-800-825-6544*For application assistance:
1-800-825-9050*

Saint Barthélemy d'Anjou, France

+33 (0) 2 41 21 24 24

Bauer Gear Motor

Bauer Gear Motor GmbH

Eberhard-Bauer-Straße 37

73734 Esslingen - Germany

+49 711 3518 0**+49 711 3518 381** (Fax)**Bauer Gear Motor
Slovakia s.r.o.**

Tovarenská 49

953 01 Zlate Moravce - Slovakia

+421 37 6926100**+421 37 6926181** (Fax)**Bauer Gear Motor Limited**

Nat Lane Business Park

Winsford, Cheshire

CW7 3BS - United Kingdom

+44 1606 868600**+44 1606 868603** (Fax)**Bauer Gear Motor LLC**

31 Schoolhouse Rd.

Somerset NJ 08873-1212 - USA

+1 732 469 8770**+1 732 469 8773** (Fax)**Altra Industrial Motion
(Shenzhen) Co., Ltd.**

18 Huan Zhen Road Dabo

Industrial Zone - BoGoang Village

ShaJing Town - BaoAn District

Guangdong Province

518104 Shenzhen City - China

+86 755 27246308**+86 755 27246017** (Fax)**Altra Industrial Motion 000**

Volokolamskoye sh., 142, bldg 6

Business Center „Irbis“

125464 Moscow - Russia

+7 495 6420468**+7 495 6420469** (Fax)**Customer Centre Finland**

01510 Vantaa

+358 207 189700**Customer Centre France-Benelux**

Brussel (Anderlecht)

+32 2 5295941**Customer Centre Italy**

Grisignano di Zocco (VI)

+39 0444 414392

Bauer assumes no liability or responsibility for misprints and errors in catalogues, brochures and other printed documentation. Bauer reserves the right to make changes to products without prior notice, including to products that have already been ordered, unless contractual technical specifications are affected by such changes. All trademarks in these publications are the sole and exclusive property of the relevant companies. Bauer and the Bauer logo are trademarks of Bauer Gear Motor GmbH. All rights reserved.

Images: Fotolia, Altra and Bauer Archive, C.H. Schäfer Getriebe GmbH, Huber SE