

# E

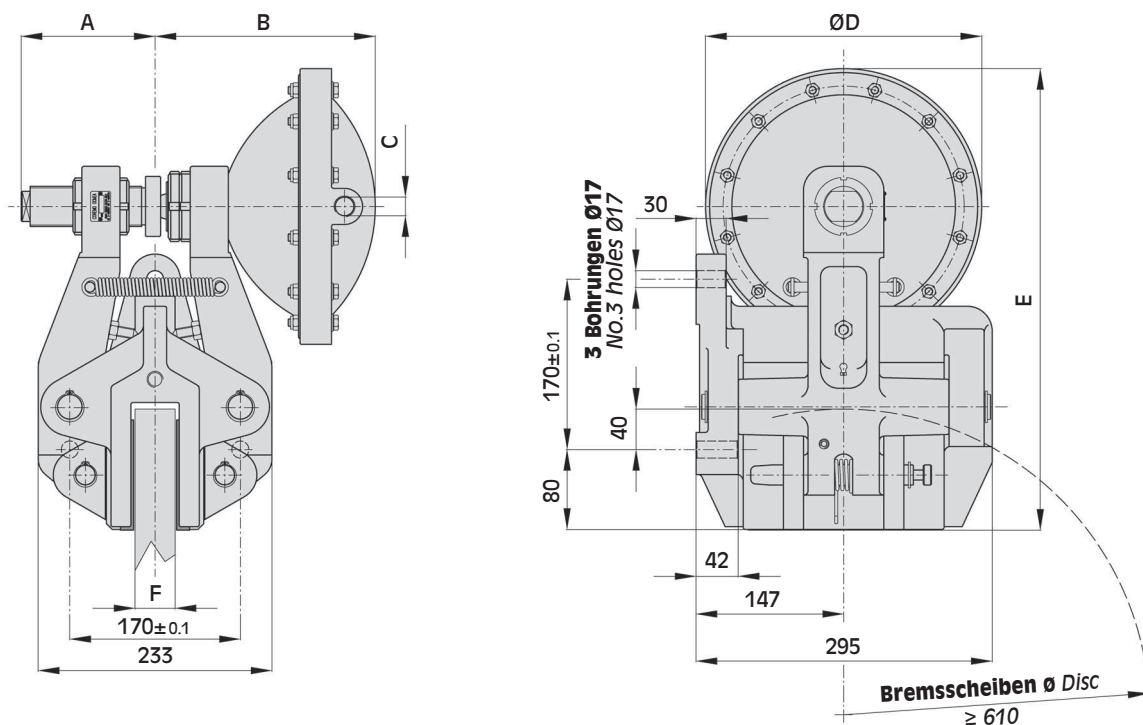
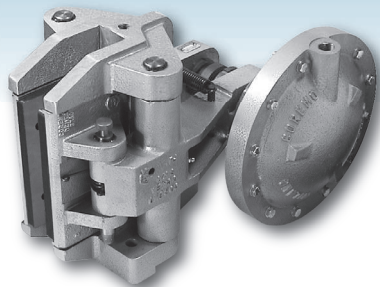

## ABMESSUNGEN/DIMENSIONS

TYP SIZE	Teil-Nr Product Number	A	B	C	ØD	E	F	Luftvolumen Air Volume dm <sup>3</sup>	Gewicht Weight kg
E3	A1955	126	180	3/8" Anschluss	184	415	25.4	0.4	57
	A1949	126	180	3/8" Anschluss	184	415	40	0.4	57
E4	A1940	135.5	219.5	1/2" Anschluss	275	460	25.4	1.2	63
	A1934	135.5	219.5	1/2" Anschluss	275	460	40	1.2	63

**Warnung:** Das anfängliche Bremsmoment neuer Bremsen/Bremsbeläge kann um 30-50% zu den Katalogwerten verringert sein, bis Bremsbeläge u. -scheiben eingelaufen sind!  
**Warning:** The initial torque on new units can be 30% to 50% less than the catalogue value until the friction facing and friction disc are lapped or worn in.

## Techn. Daten

Bremskraft F:

<b>E3</b>	20180 N bei 6 bar
<b>E4</b>	36600 N bei 6 bar

dyn. Bremsmoment:  
 $= F \cdot (\text{Scheibenradius(m)} - 0.065) = \text{Nm}$

Max. Belagverschleiss: 12 mm

Bremsbelagsdicke (neu): 13 mm

Dauerwärmeleistung: Qc: 20 kW

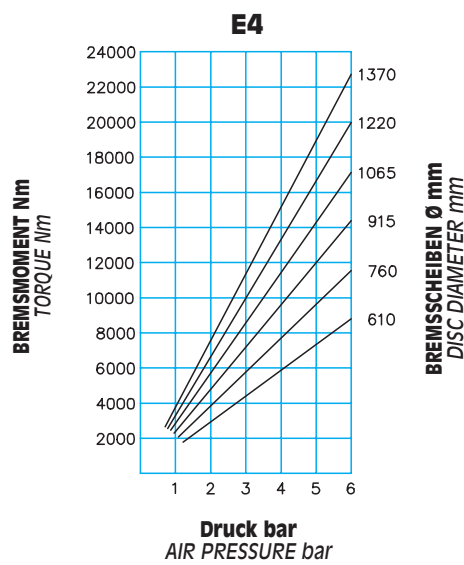
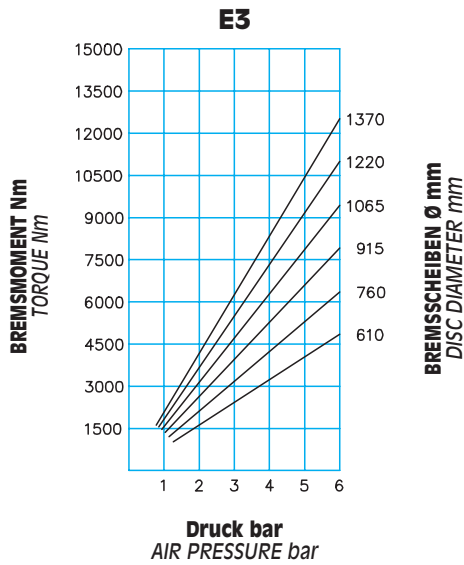

## DIAGRAMM/CHART

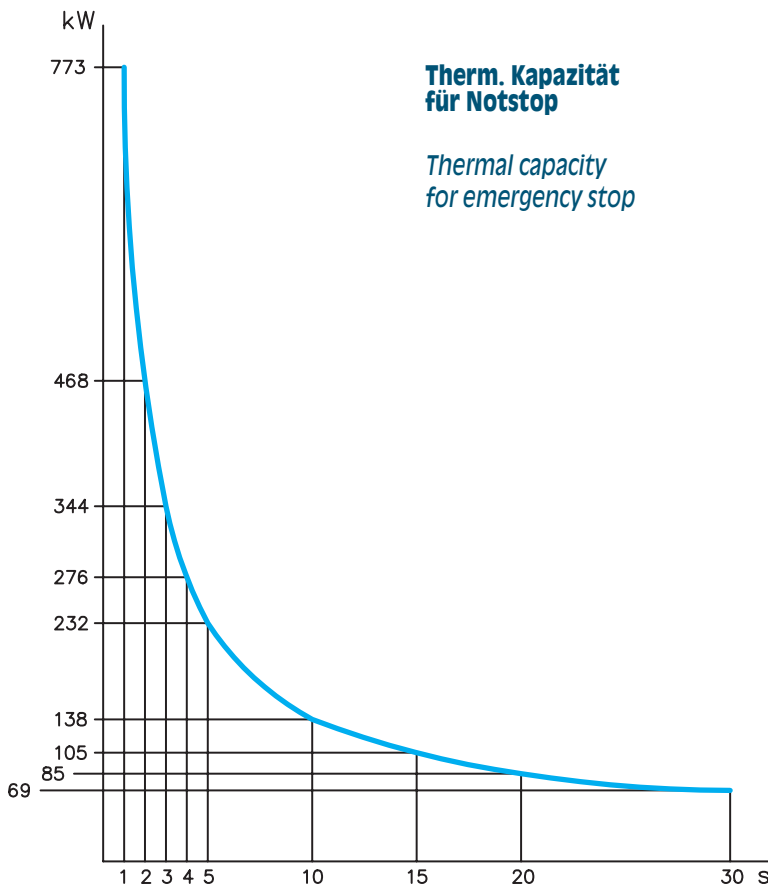

## Technical data

Braking force F:

<b>E3</b>	20180 N at 6 bar
<b>E4</b>	36600 N at 6 bar

Dynamic torque  
 $= F \cdot (\text{disc radius in m} - 0.065) = \text{Nm}$

Max total wear: 12 mm

Thickness of new lining: 13 mm

Continuous thermal capacity  
 Qc: 20 kW