

EL-M

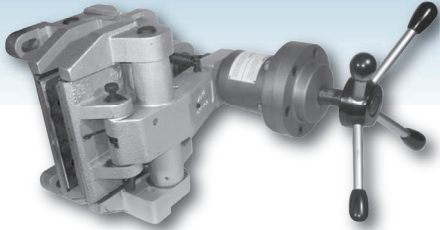

Front Ansicht Anschraubfläche
Frontal mounting view

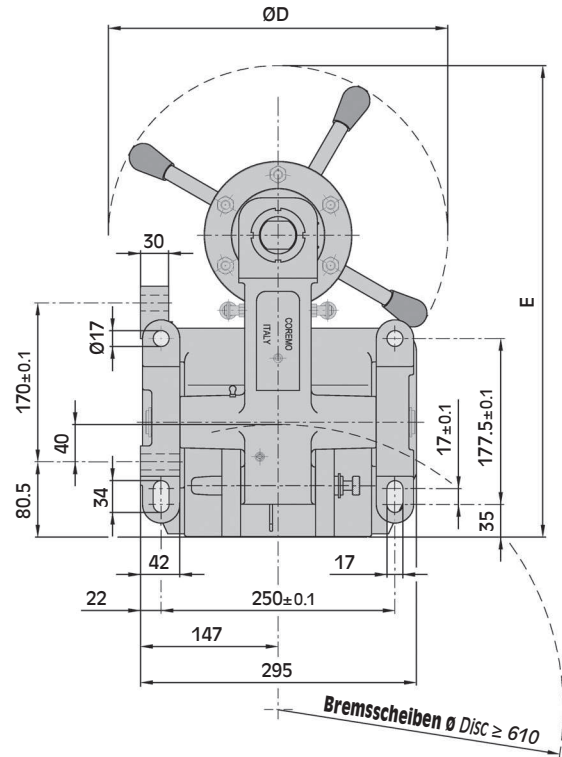
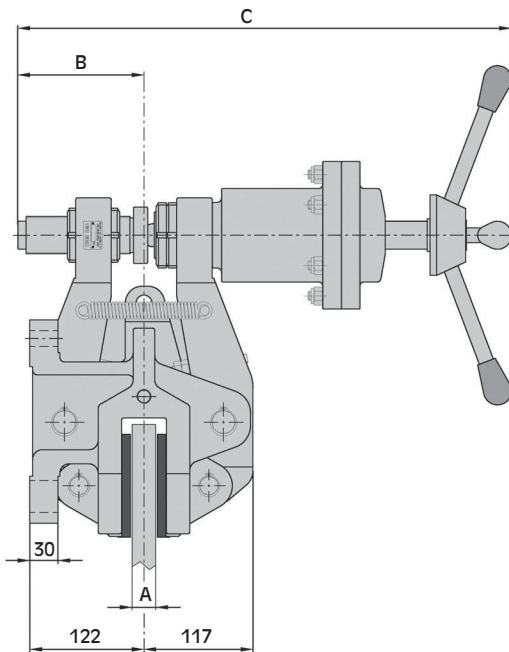
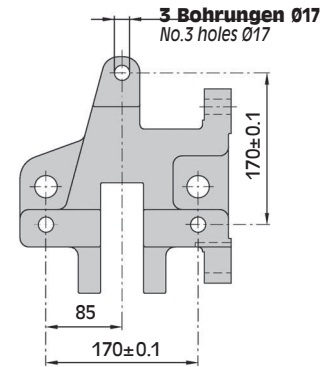

ABMESSUNGEN/DIMENSIONS

TYP SIZE	Teil-Nr Product Number	A	B	C	ØD	E	Gewicht Weight kg
EL-M	A3622	25.4	135	528	363	504	72
	A3625	40	135	528	363	504	72

Warnung: Das anfängliche Bremsmoment neuer Bremsen/Bremsbeläge kann um 30-50% zu den Katalogwerten verringert sein, bis Bremsbeläge u. -scheiben eingelaufen sind!
Warning: The initial torque on new units can be 30% to 50% less than the catalogue value until the friction facing and friction disc are lapped or worn in.

Techn. Daten

Bremskraft F:

EL-M 39800 N 16 Umdrehungen Handrad

dyn. Bremsmoment:
 $= F \cdot (\text{Scheibenradius(m)} - 0.065) = \text{Nm}$

Max. Belagverschleiss: 12 mm

Bremsbelagsdicke (neu): 13 mm

Dauerwärmeleistung: Qc = 20 kW

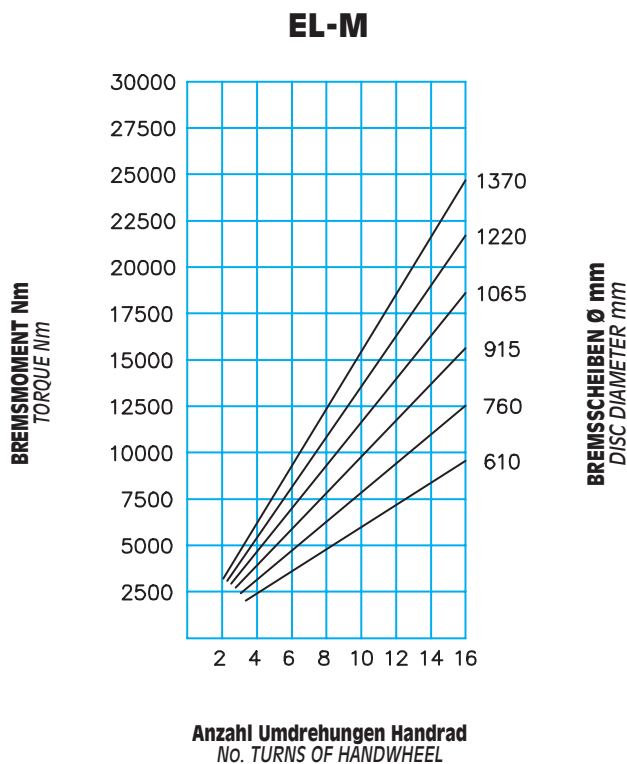

Technical data

Braking force F:

EL-M 39800 N 16 turns of handwheel

Dynamic torque
 $= F \cdot (\text{disc radius in m} - 0.065) = \text{Nm}$

Max total wear: 12 mm

Thickness of new lining: 13 mm

Continuous thermal capacity
 Qc: 20 kW