

EL-N

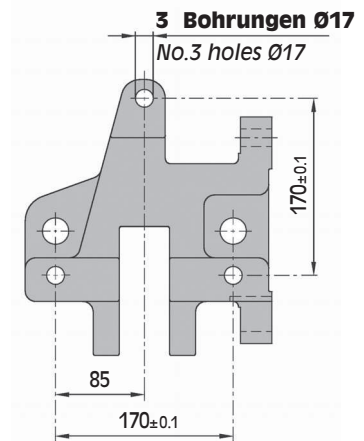

Ansicht Anschraubfläche Bremse
Frontal mounting view

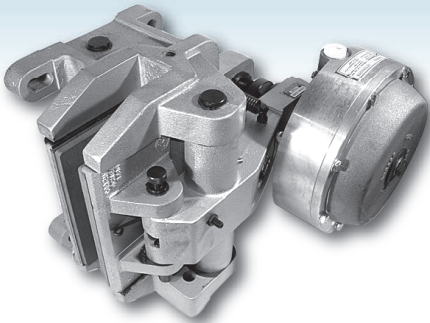
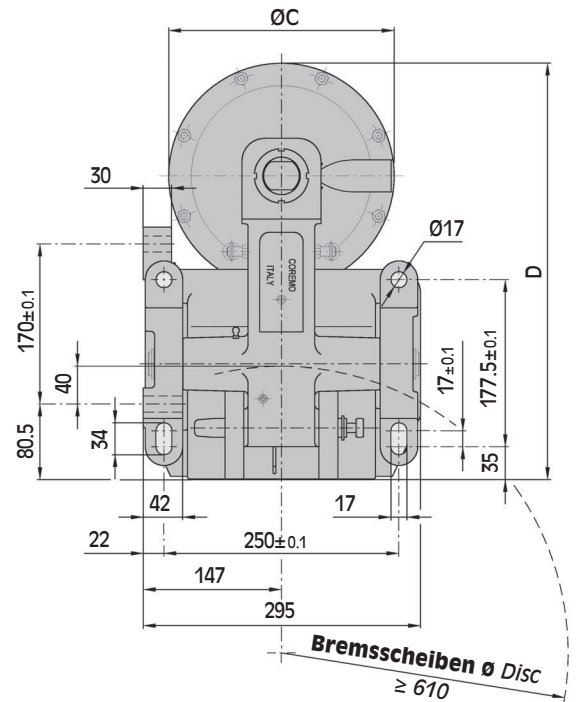
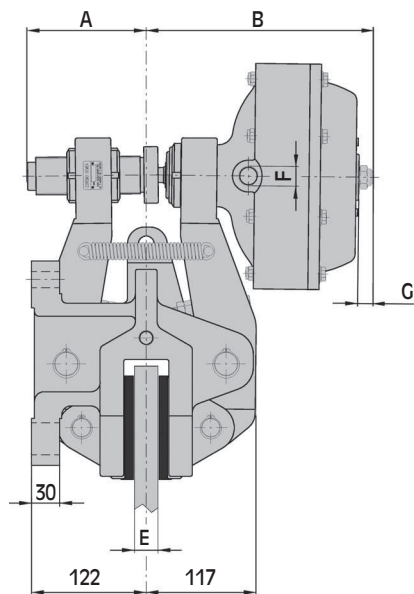

ABMESSUNGEN/DIMENSIONS

TYP SIZE	Teil-Nr Product Number	A	B	ØC	D	E	F	G	Luftvolumen Air Volume dm ³	Gewicht Weight kg
EL-3N	A3587	126	227	190	418	25.4	1/2" Anschluss	14	0.7	64
	A3590	126	227	190	418	40	1/2" Anschluss	14	0.7	64
EL-3.5N	A3593	127	242	240	443	25.4	1/2" Anschluss	16	0.95	68.5
	A3596	127	242	240	443	40	1/2" Anschluss	16	0.95	68.5
EL-4N	A3599	135	289	280	463	25.4	1/2" Anschluss	16	3	73
	A3602	135	289	280	463	40	1/2" Anschluss	16	3	73

Warnung: Das anfängliche Bremsmoment neuer Bremsen/Bremsbeläge kann um 30-50% zu den Katalogwerten verringert sein, bis Bremsbeläge u. -scheiben eingelaufen sind!
Warning: The initial torque on new units can be 30% to 50% less than the catalogue value until the friction facing and friction disc are lapped or worn in.

Techn. Daten

Bremskraft F:

EL-3N	14150 N
EL-3.5N	26600 N
EL-4N	32000 N

dyn. Bremsmoment:
 $= F \cdot (\text{Scheibenradius(m)} - 0.065) = \text{Nm}$

- Max. Belagverschleiss: 12 mm
- Bremsbelagsdicke (neu): 13 mm
- Dauerwärmeleistung: $Q_c = 20 \text{ kW}$
- Min. Öffnungsdruck: 5 bar

Die Br.-Momente beziehen sich auf
 8 Bet.-Federn (3N)
 12 Bet.-Federn (3.5N & 4N)
 Proportional geringere Br.-Momente sind erreichbar durch den Einsatz von
 6-4-2 Bet.-Federn (3N)
 10-8-6 Bet.-Federn (3.5N & 4N)

Das Diagramm zeigt die Bremsmomentabweichungen je 1 mm Belagverschleiss. Für gleichbleibendes Br.-Moment muss die Bremse entsprechend nachjustiert werden.

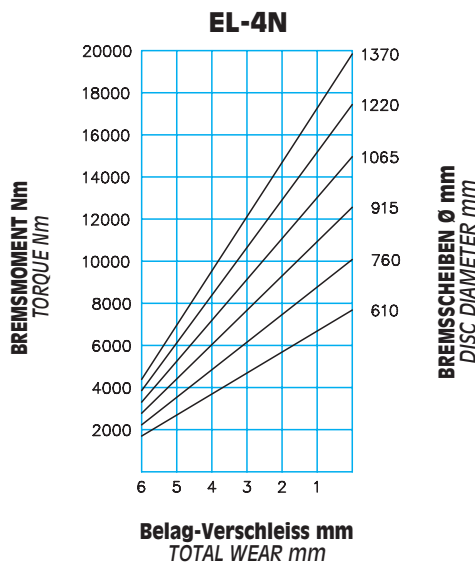
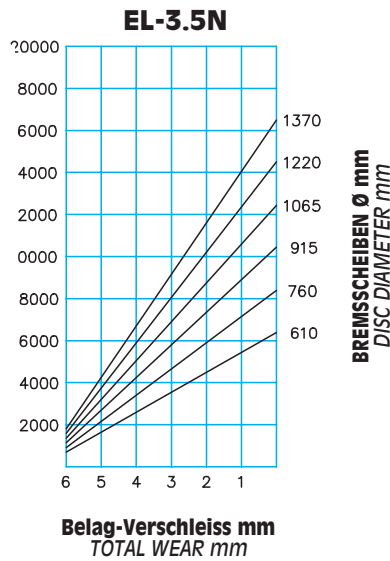
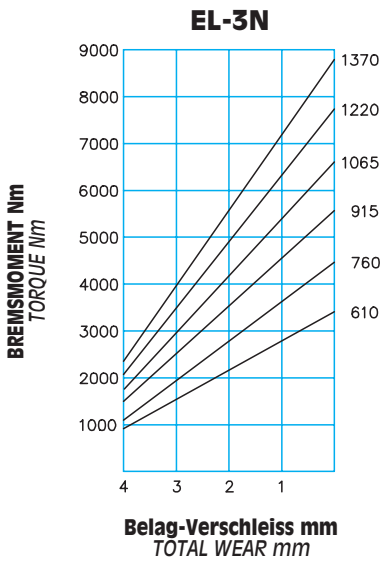

Technical data

Braking force F:

EL-3N	14150 N
EL-3.5N	26600 N
EL-4N	32000 N

Dynamic torque
 $= F \cdot (\text{disc radius in m} - 0.065) = \text{Nm}$

Max total wear: 12 mm

Thickness of new lining: 13 mm

Continuous thermal capacity
 $Q_c: 20 \text{ kW}$

Minimum release pressure: 5 bar

The torque values specified are obtained with
 No. 8 springs for 3N,
 No. 12 springs for 3.5N and 4N.
 Torque proportionally less are achievable with
 No. 6-4-2 springs for 3N,
 No. 10-8-6 springs for 3.5N and 4N.
 The diagram shows the torque variation for each millimeter of linings wear.
 Adjust according to ensure the correct torque value is achieved.

DIAGRAMM/CHART

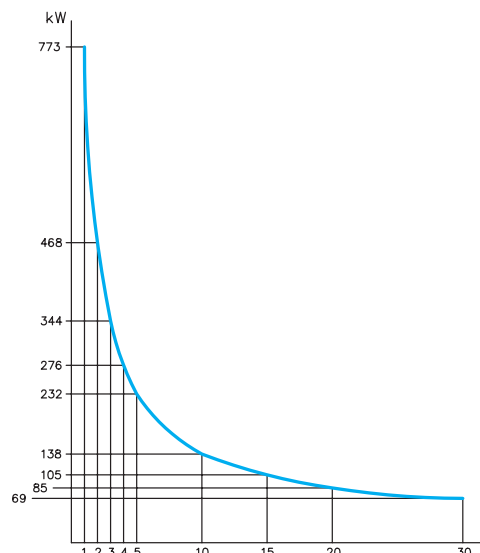

Therm. Kapazität für Notstop

Thermal capacity for emergency stop